



Exedra2

SALICE

Exedra2



Exedra2 Star and **Exedra2 Smart** are evolutions of the Exedra system, which, thanks to an innovatively-engineered mechanism, enable the simultaneous movement of two linked doors.

It is a patented mechanism with assisted door extraction and door insertion, operated by a magnetically-assisted motion-control system that confers a smooth and perfectly balanced movement.

Versions: Design options: the STAR version, where the mechanism remains concealed behind the cover panel, and the SMART version, which reveals the door edges when folded in the pocket. With three opening mechanisms-traditional, handle-less Push, or fully motorized-Exedra2 provides an ideal solution for any design requirement.

Flexible: Exedra2 can accommodate a wide range of doors, with height from 1800 mm to 2700 mm, width from 350 mm to 757 mm (STAR version) and from 525 mm to 860 mm (SMART version).

Fluid and controlled: eliminating the need for cables, tie rods, or springs, the Exedra2 technology uses the force of gravity, along with the magnetic dampers that control the doors, offering a fluid, silent and long-lasting movement, tested up to 50,000 cycles.

The system is compatible with Exedra Gravity and can be developed directly with the online configurator.



Exedra2 Star • Exedra2 Smart



Technical Information

DOUBLE pocket door system with cam-assisted door extraction and cushioned door insertion.

Door characteristics:

- Maximum weight for single door: 25 Kg
- Doors thickness: min 18 mm - max 25 mm
- Width of single door – Exedra2 Star: min 350 mm - max 757mm
- Width of single door – Exedra2 Smart: min 525 mm - max 860 mm
- Doors height: min 1800 mm - max 2700 mm

Adjustment:

- vertical adjustment ± 5 mm
- horizontal adjustment ± 3.5 mm
- front adjustment: - upper ± 3 mm
- lower ± 2 mm

Exedra2 Star

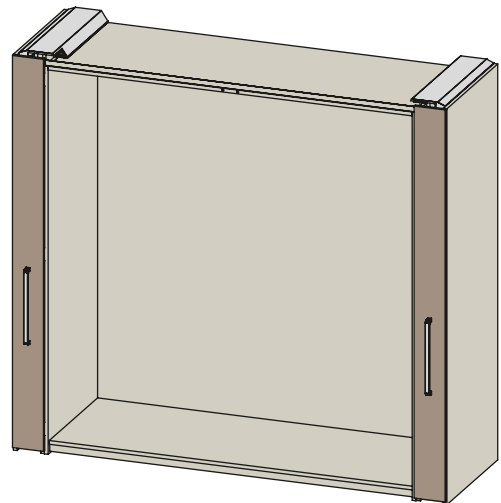
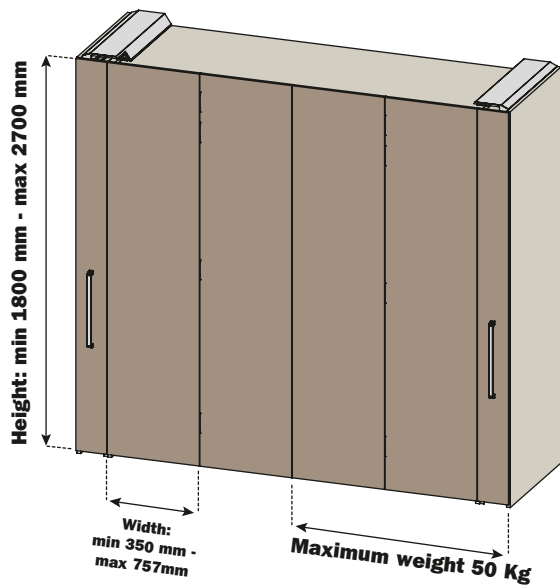

Exedra2 Smart

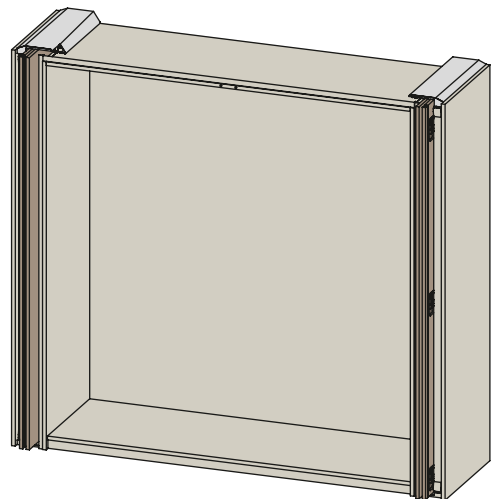
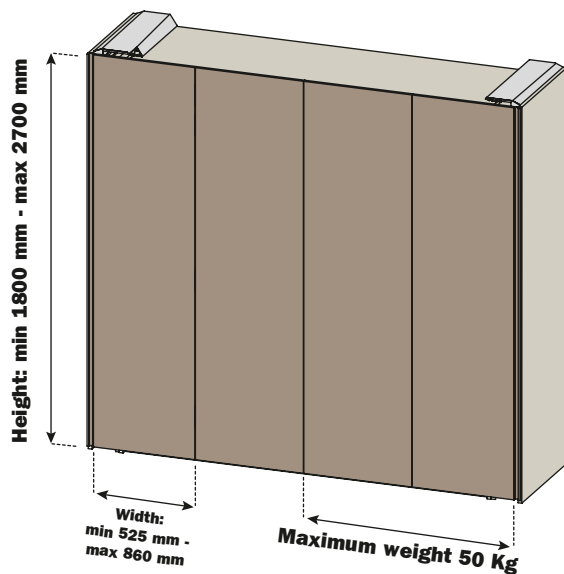

- 1** - Unique on the market, this patented door opening system has a inward folding design which remains scratch free during operation.
- 2** - None load-bearing track on the top of the cabinet.
- 3** - Magnetic buffer for assisted cushioned doors insertion.
- 4** - Structural aluminium frame for doors movement.
- 5** - Frontal insertion of the load-bearing frame facilitating its installation in a wall recess.
- 6** - Side frame to support the lower load-bearing track. All of the load is carried by the side panel. The track does not require ground support.
- 7** - Anti-crush device.

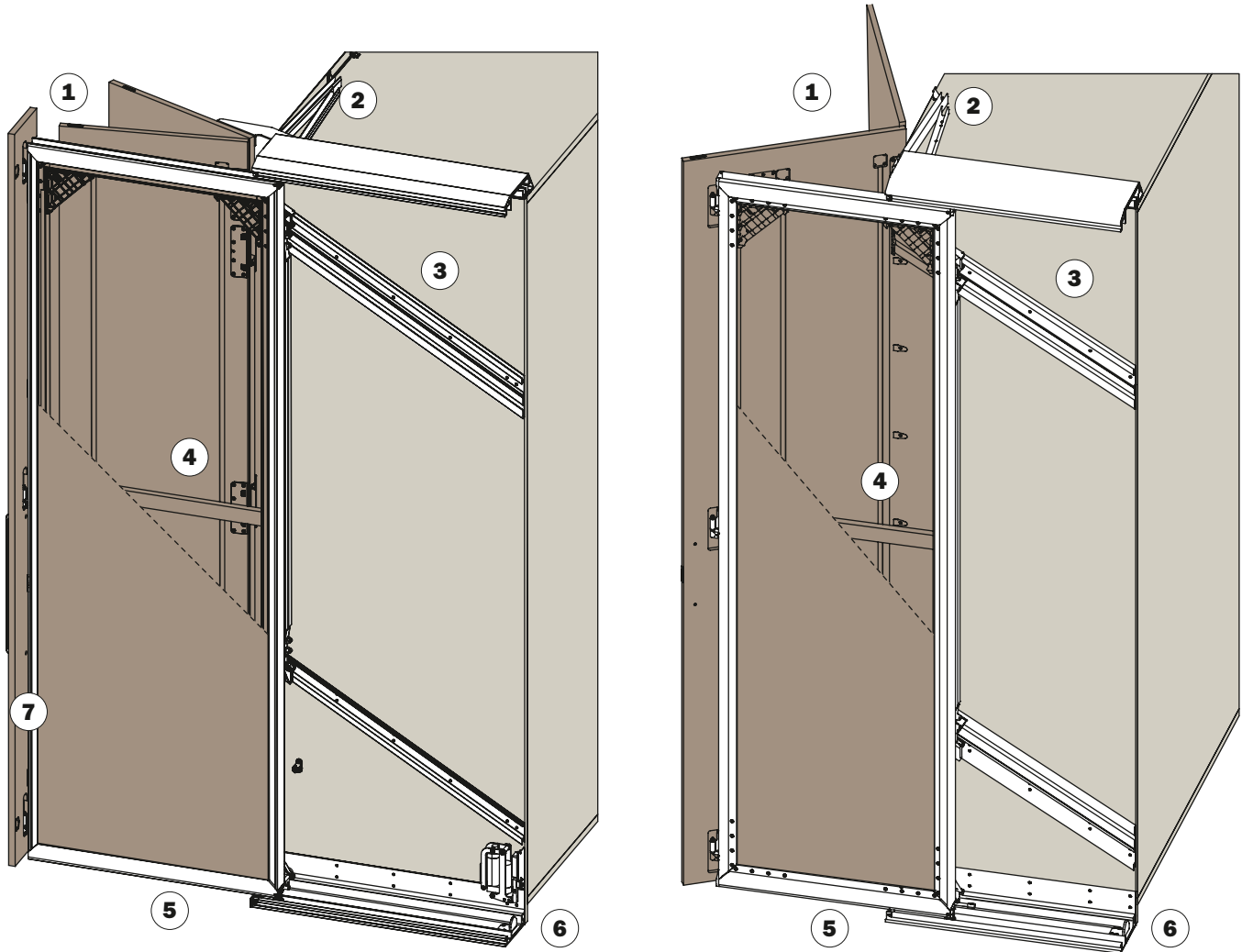

Exedra2 Star

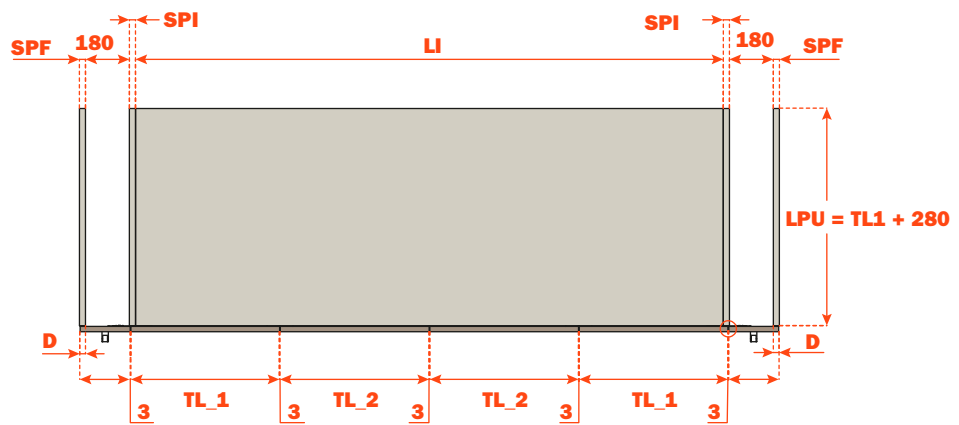
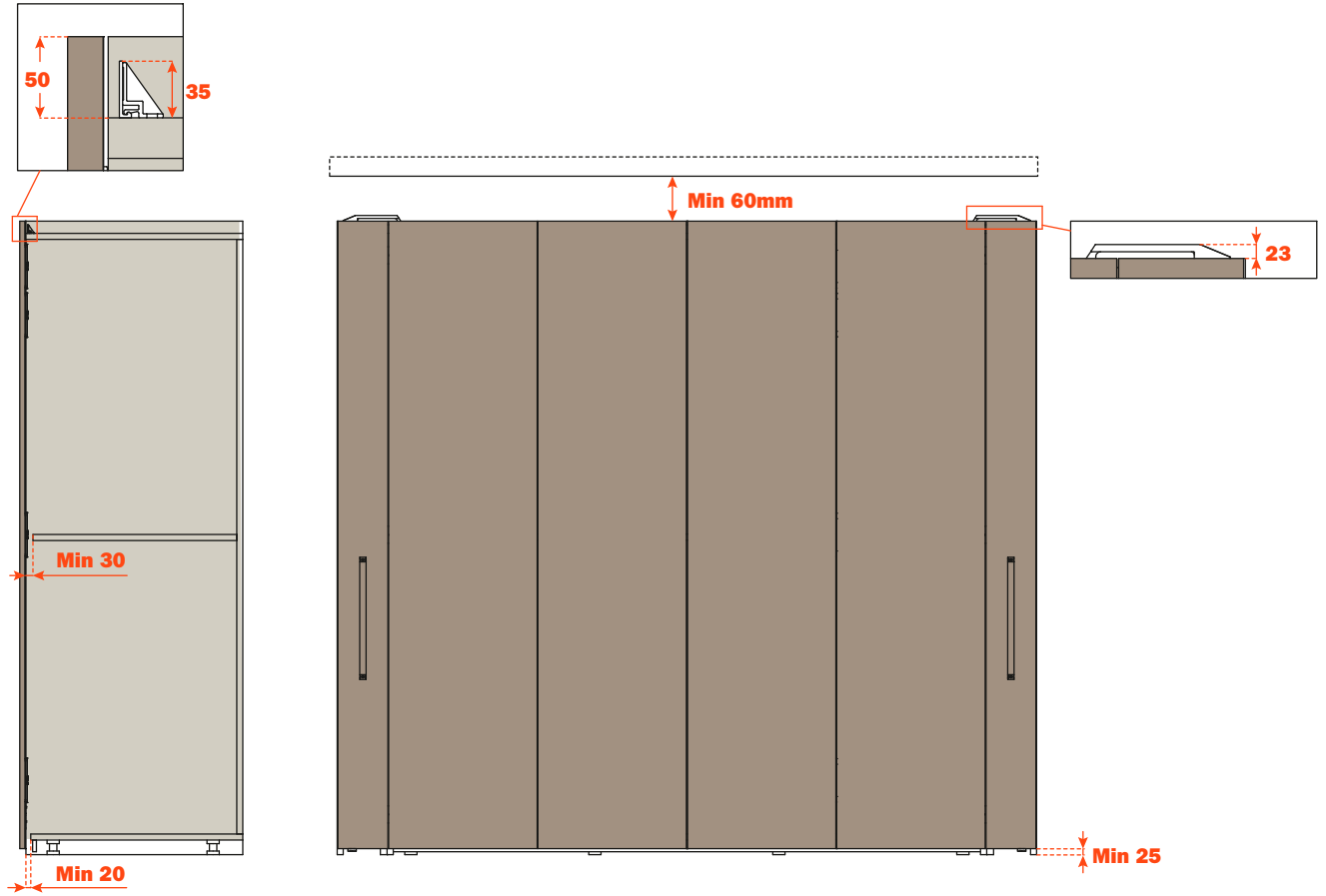

Exedra2 Smart

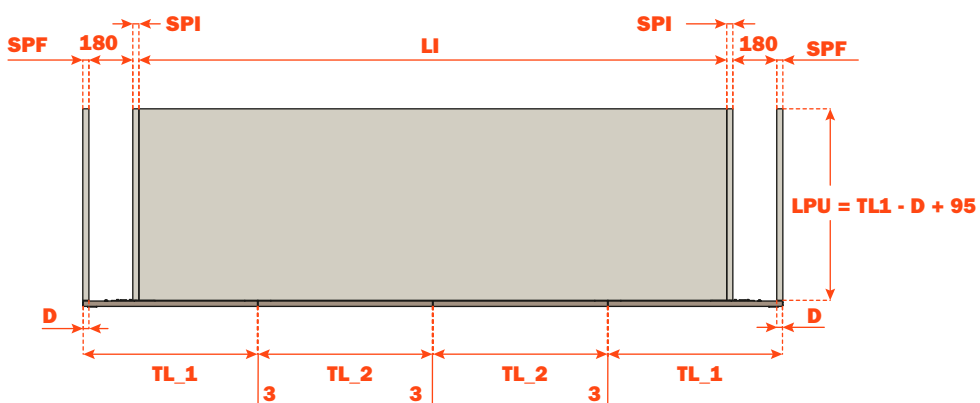
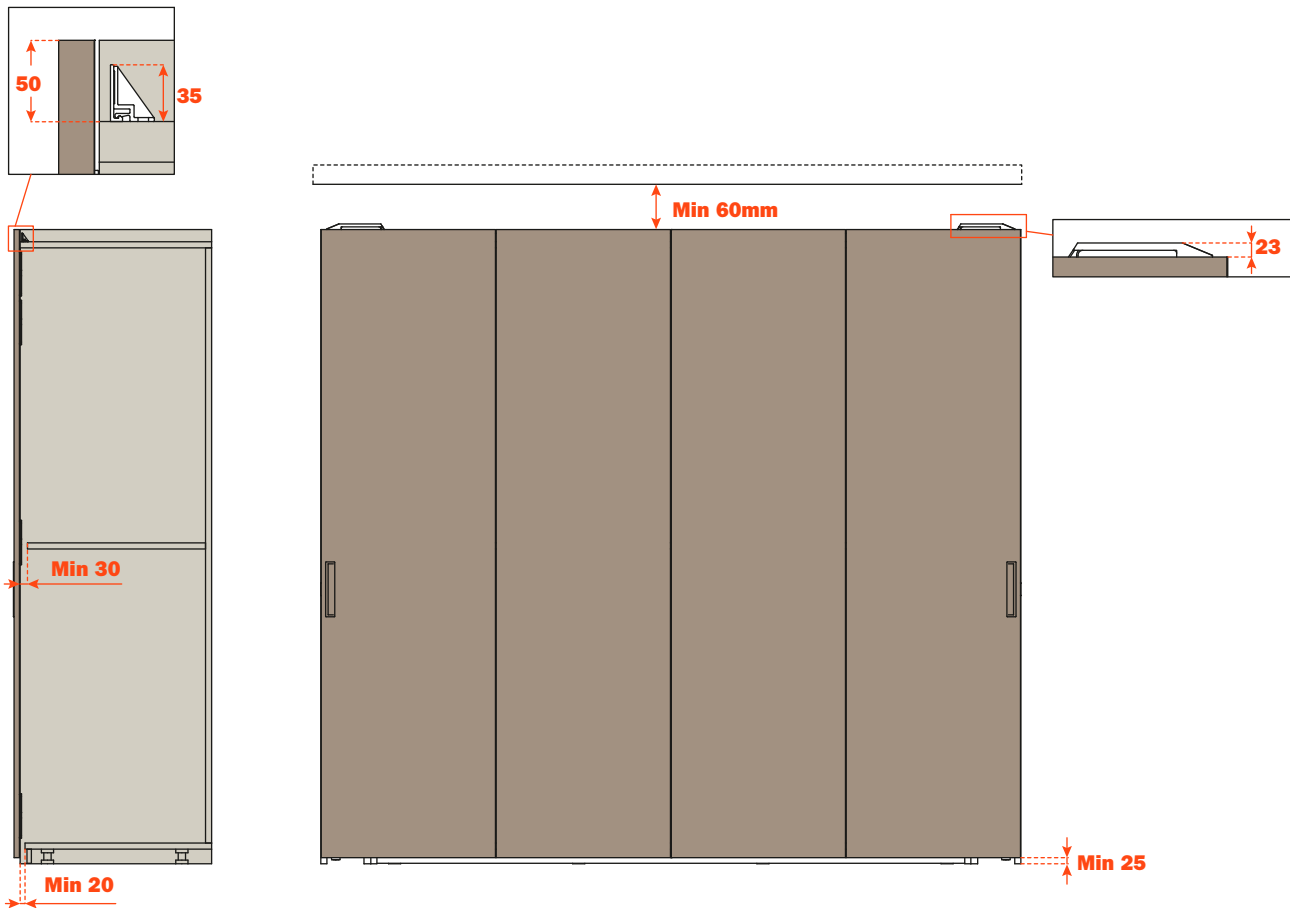

Exedra2 Assembly and examples

The right mechanism and the left mechanism are independent of each other, therefore it is possible to order them individually. If they are installed on the same cabinet, they must be configured as a pair.

Versions: Design options: the STAR version, where the mechanism remains concealed behind the cover panel, and the SMART version, which reveals the door edges when folded in pocket. With three opening mechanisms-traditional, handle-less Push, or fully motorized-Exedra2 provides an ideal solution for any design requirement.

Exedra2 Star is the version where the compartment that houses the mechanism is always hidden by the cover panel which is fixed to the front of the system.

Single door, left mechanism

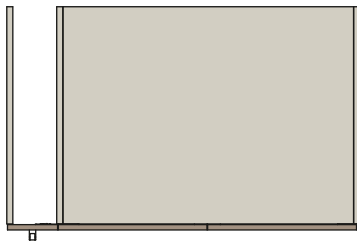

Single door, right mechanism

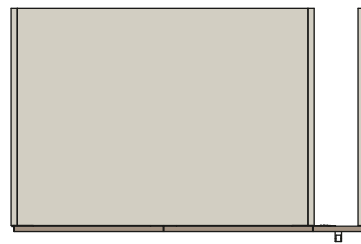

Double doors, pair of mechanism (left and right)

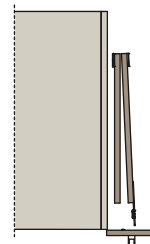

Exedra2 Smart is the version that requires less depth of the cabinet; the door edges are visible when they are folded into their compartment.

Single door, left mechanism



Single door, right mechanism



Double doors, pair of mechanism (left and right)

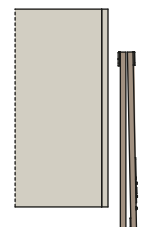

The Exedra2 system is the ideal mechanism in a host of applications. The absence of a frontal lower track makes it adaptable to any application, from traditional cabinets to walk-in wardrobes.

The system does not necessarily have to be placed on the floor, therefore it is possible to create systems raised from the ground or placed on a cupboard or a chest of drawers.

Thanks to the innovative door movement system with its moving load-bearing frame, the weight of the system and the doors is carried solely by the side of the cabinet; the system places no load on the top of the cabinet. As a result, double systems with an enormous free internal span of 2700 mm are possible without requiring a central panel or support.

Exedra2 Star

Traditional

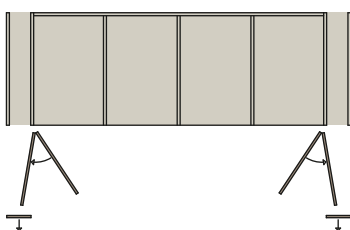
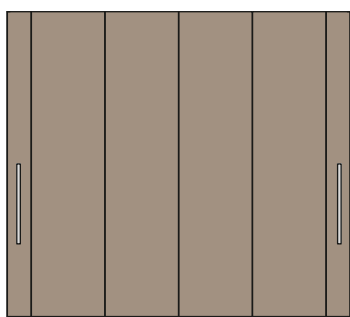

In wall recess

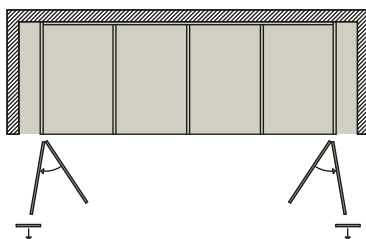
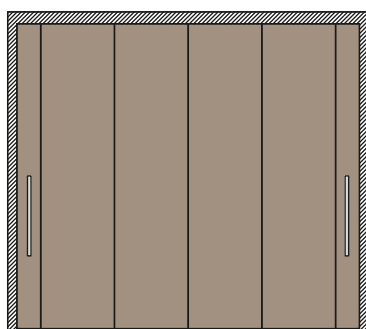

Raised from the ground

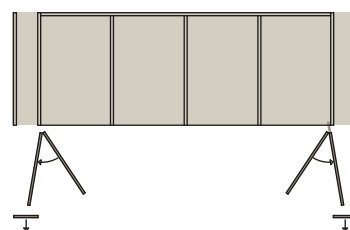
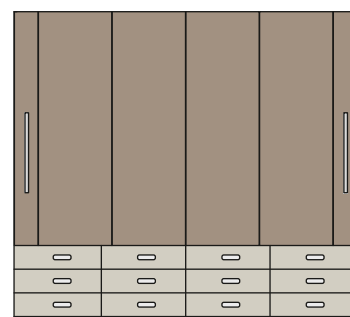

Exedra2 Smart

Traditional

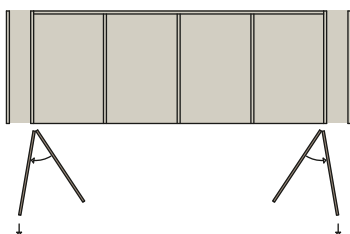
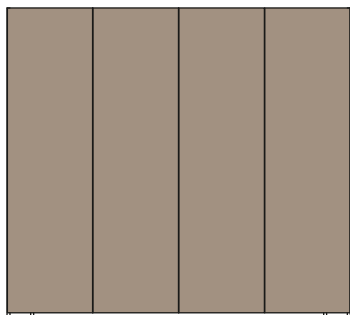

In wall recess

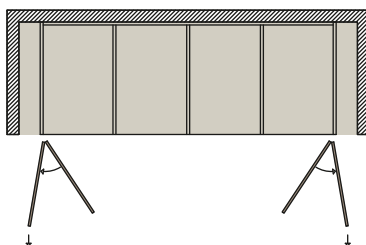
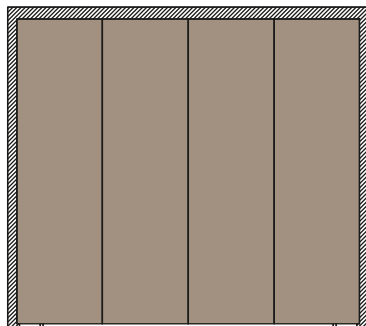

Raised from the ground

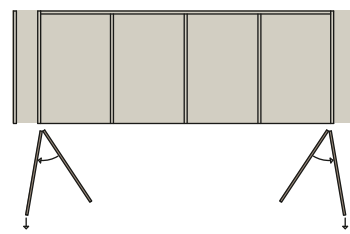
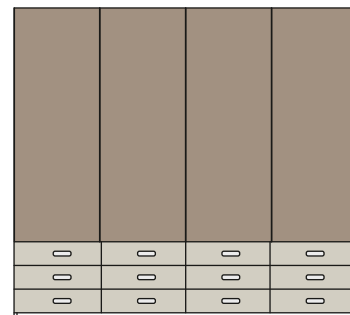





Optional

Exedra2

Magnets kit to protect doors.

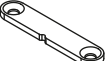
It is required to maintain the minimum distance between the doors during the folding phase and to prevent accidental collisions between the doors in case of improper use of the mechanism.

| | | | | |
|---|---|---|----------------------------------|------------------------------|
|  |  |  | Part number VE56KIT001 | Magnets kit to protect doors |
|---|---|---|----------------------------------|------------------------------|

Smove kit for internal door.

It is required to prevent any impact and/or contact between the internal door and the top of the cabinet during the closing movement.

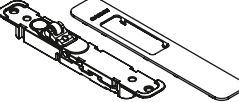
| | | |
|---|----------------------------------|-----------------------------|
|  | Part number VE56KIT002 | Smove kit for internal door |
|---|----------------------------------|-----------------------------|

Doors alignment kit.

It is required to align the doors in applications with a pair of Exedra2 (right + left).

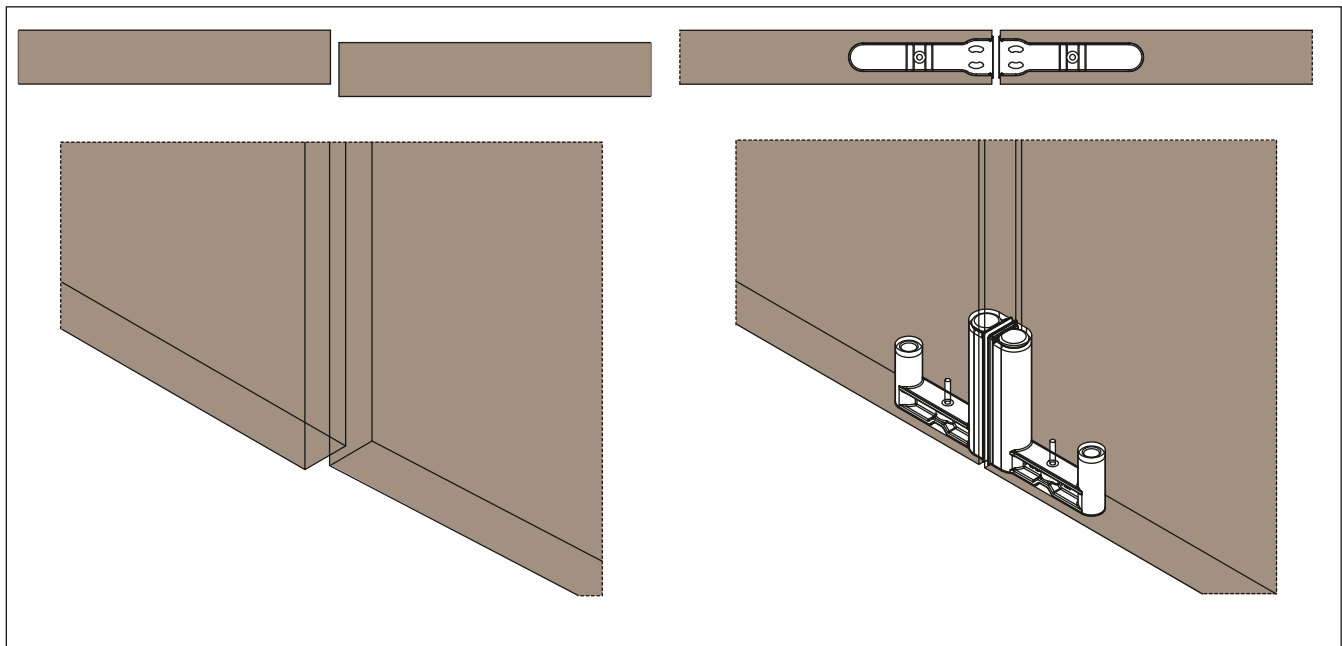

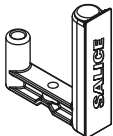
| | | |
|---|--------------------|---------------------|
|  | Part number | |
| | VE56KIT0003 | Doors alignment kit |

Frame cover for Exedra2 Smart

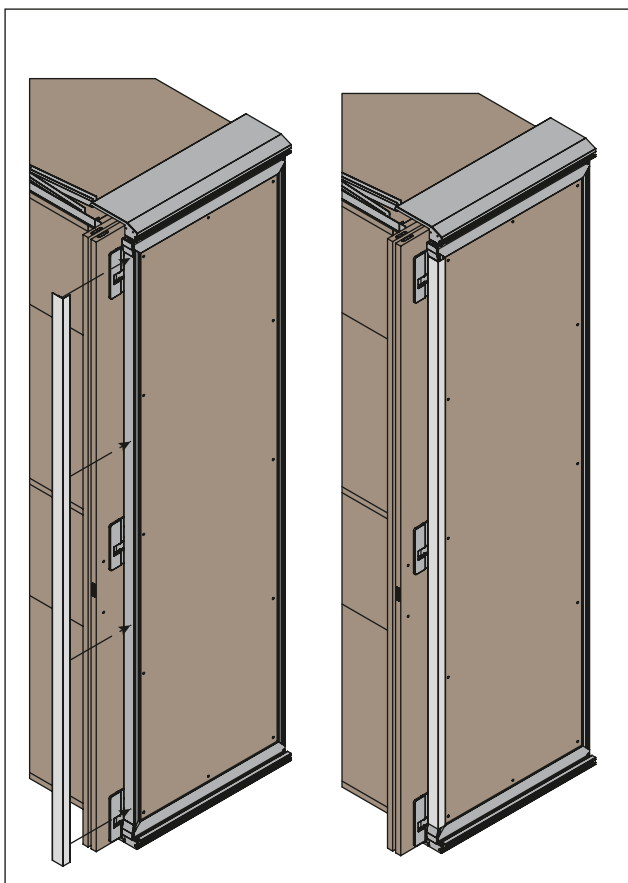

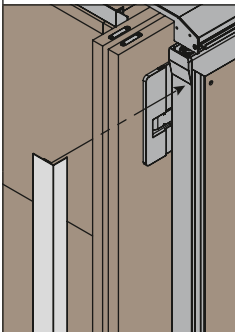
| | | |
|--|--------------------|--|
|  | Part number | |
| | VE56KIT0200A7 | Frame cover can be coated by the customer L = 2600 mm |
| | VE56KIT0200S7 | Frame cover metal grey L = 2600 mm |

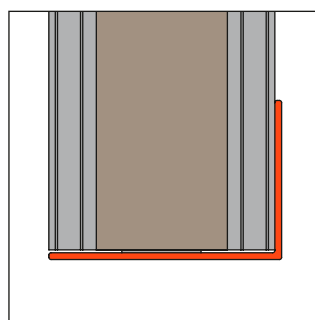

Exedra2

Mechanical Push Kit

The Push Kit can be included when ordering a custom mechanism or ordered separately to update existing mechanisms.

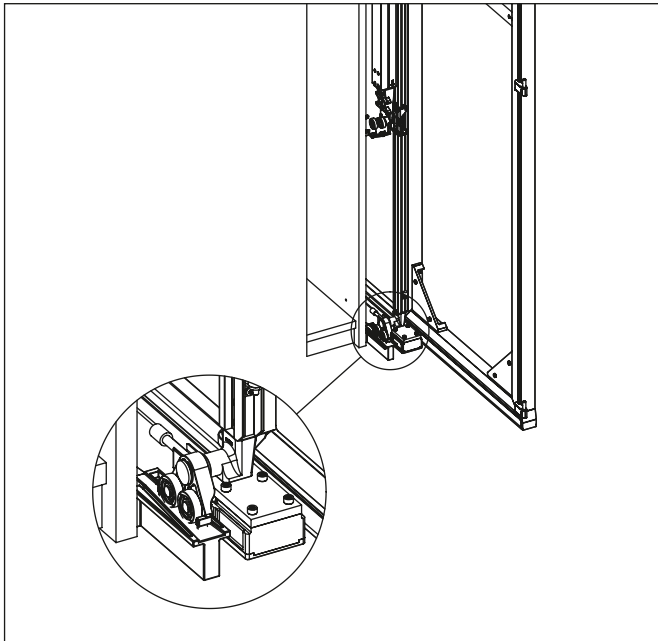

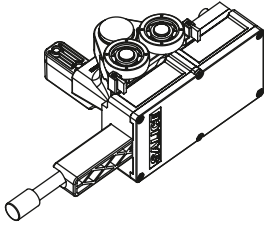
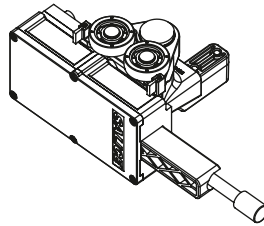
| | Codice | |
|--|---------------|----------------------------------|
|  | VE56KIT0020 | Push kit right mobile side |
|  | VE56KIT0022 | Push kit left mobile side |

Mode of operation.

A slight pressure on the external door or on the cover panel activates the electrical system and the door moves outwards by approx. 50 mm.

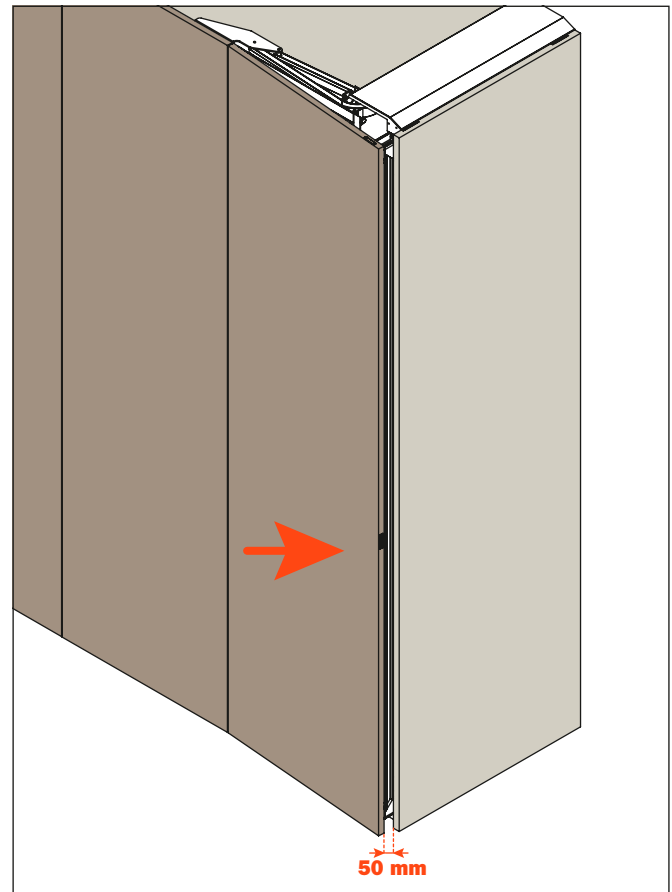
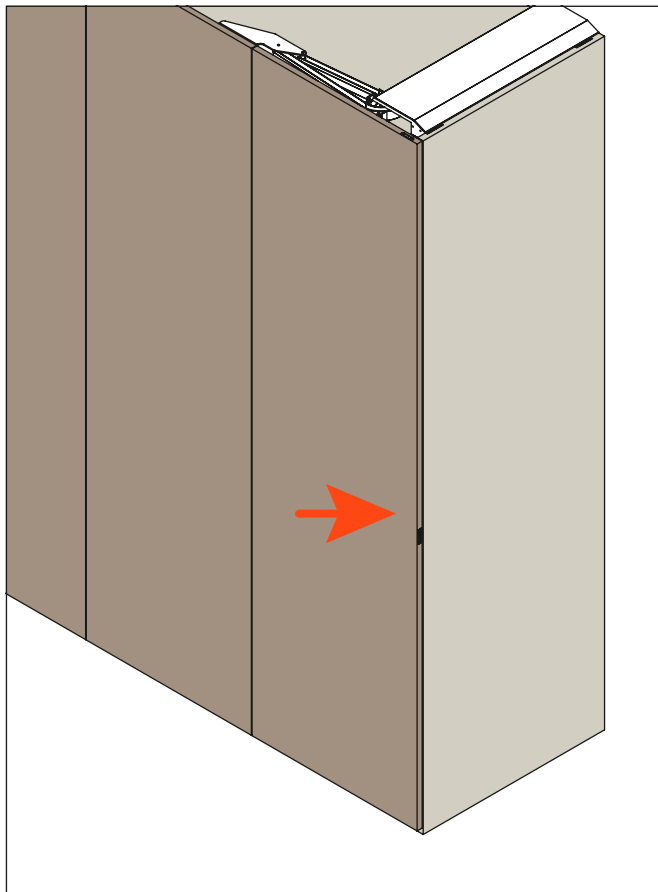

Motorised application

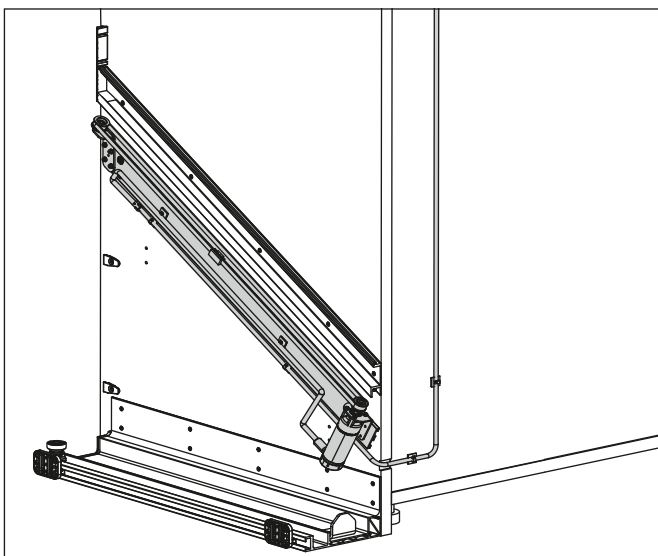
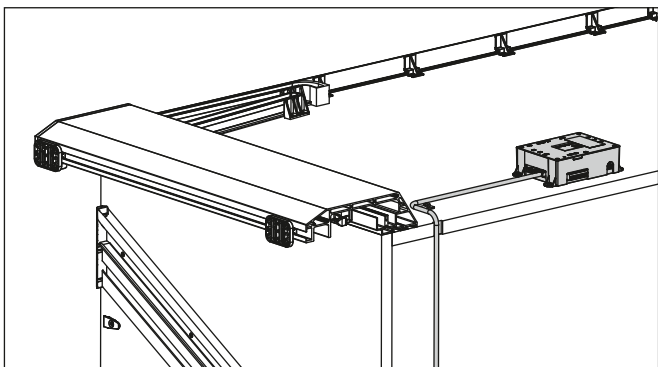

Motorisation can be requested when ordering the mechanism.

The movement can be activated with the following methods:

- a touch-activated capacitive sensor discreetly mounted inside the door.
- remote control with receiver card to be connected to the general control unit.

Both control options can activate the doors synchronously or independently, and they can operate in conjunction.

Control type kit

| | |
|--|------------------------------|
| | <p>Capacitive sensor kit</p> |
| | <p>Remote control kit</p> |

HEADQUARTERS AND PRODUCTION UNITS

ARTURO SALICE S.p.A.

HEAD OFFICE

VIA PROVINCIALE NOVEDRATESE, 10
22060 NOVEDRATE (COMO) ITALIA
TEL. 031 790424 - FAX 031 791508
info.salice@salice.com
www.salice.com

ARTURO SALICE S.p.A.

VIA ARISTIDE MERLONI, 11
61036 COLLI AL METAURO (PU) ITALIA
TEL. 0721 899800
FAX 0721 897980
info.salice@salice.com
www.salice.com

BORTOLUZZI SISTEMI S.p.A.

VIA CADUTI 14 SETTEMBRE 1944, 45
32100 BELLUNO (BL) ITALIA
TEL. 0437 930866
FAX 0437 931442
info@bortoluzzi.com
www.salice.com

NUOVA ATIM S.r.l.

VIA IV NOVEMBRE, 52
20019 SETTIMO MILANESE (MI) ITALIA
TEL. 02 33503203
FAX 02 33516514
info@atimspa.com
www.atimspa.com

BRANCHES

DEUTSCHE SALICE GMBH

RUDOLF DIESEL STR. 10
74382 NECKARWESTHEIM
TEL. 07133 9807-0
FAX. 07133 9807-16
info.salice@deutschesalice.de
www.salice.com

DEUTSCHE SALICE GMBH

VERKAUFSBÜRO NORD
RINGSTRASSE 36/A30 CENTER
32584 LÖHNE
TEL. 05731 15608-0
FAX. 05731 15608-10
vknord@deutschesalice.de
www.salice.com

SALICE UK LTD.

KINGFISHER WAY
HINCHINGBROOKE BUSINESS PARK
HUNTINGDON CAMBS PE 29 6FN
TEL. 01480 413831
FAX. 01480 451489
info.salice@saliceuk.co.uk
www.salice.com

SALICE FRANCE S.A.R.L.

285 RUE DE GOA ZAC LES 3 MOULINS
06600 ANTIBES
TEL. 0493 330069
FAX. 0493 330141
info.salice@salicefrance.com
www.salice.com

SALICE ESPAÑA, S.L.U.

C/ AIGUAFREDA 4, P.I. AMETLLA PARK
08480 L'AMETLLA DEL VALLÈS (BARCELONA)
TEL. 0034 938 46 88 61
info.salice@saliceespana.es
www.salice.com

SALICE PORTUGAL UNIP. LDA

SHOWROOM:
TV SÁ E MELO 161 FA
4470-116 MAIA - PORTO
TEL: 00351 224 154 221
Info@saliceportugal.pt
www.salice.com

ARMAZÉM:
VIA ROTA DOS MÓVEIS I 399
4585-325 GANDRA

SALICE CHINA (SHANGHAI) CO. LTD.

RM 602, 6/F, TOWER 1,
3688 YINGGANG DONG ROAD
QINGPU DISTRICT
201703 SHANGHAI, CHINA
TEL. 021 3988-9880
info.salice@salicechina.com
www.salicechina.com

SALICE INDIA PVT. LTD.

1001 & 1002, 10TH FLOOR,
CENTRUM, PLOT NO. C-3,
OPP. WAGLE PRABHAG SAMITI OFFICE,
MIDC AREA, WAGLE INDUSTRIAL ESTATE,
THANE - 400604, MAHARASHTRA
TEL. 022 20812050
info@saliceindia.com
www.salice.com

SALICE CANADA INC.

3500 RIDGEWAY DRIVE,
UNIT#1
MISSISSAUGA, ONTARIO, L5L 0B4
TEL. 905 820 8787
FAX. 905 820 7226
info.salice@salicecanada.com
www.salicecanada.com

SALICE AMERICA INC.

2123 CROWN CENTRE DRIVE
CHARLOTTE NC. 28227
TEL. 704 841 7810
FAX. 704 841 7808
info.salice@saliceamerica.com
www.saliceamerica.com



ARTURO SALICE S.p.A.

HEAD OFFICE

VIA PROVINCIALE NOVEDRATESE, 10
22060 NOVEDRATE (COMO) ITALIA
TEL. 031 790424 - FAX 031 791508

info.salice@salice.com
www.salice.com



Digital contents

DOCASS016ENG Ed. 05 - 05/2025

